



OTS Type 2

Spiral heat exchanger for two-phase applications

Applications

The Alfa Laval OTS Type 2 spiral heat exchanger can be used as a condenser, reboiler, gas cooler and heater, in cases where one or both of the fluids may cause fouling.

Operating principles

The OTS Type 2 spiral heat exchanger features a single-channel design, which means that each fluid occupies a single channel. This enables one medium to move in a spiral flow while the other moves in a cross flow, parallel to the axis of the spiral element. The spiral-flow channel is welded shut on each side, whereas the other medium passes through the open spiral element. This design combines high liquid velocity in the closed spiral with large flow volume and low pressure drop on the cross-flow vapour side.

Self-cleaning

The single-channel construction eliminates bypassing and reduces fouling. The turbulence of the fluid in the channel constantly flushes away any scaling or deposits as soon as they form. If fouling occurs, thus diminishing the cross section of the channel, the velocity increases and scrubs away deposits at the exact zone affected.

Process efficiency

Minimal vapour pressure drop can be easily achieved, so that high-capacity vacuum systems are not needed. A large cross-flow area within a short flow length allows the handling of large volume flows in a single unit.

Small space requirement

The wrapped cylindrical arrangement of a minimized heat transfer surface results in an extremely compact unit. This compact design ensures lower capital and installation costs.

Easy access and maintenance

The compact design of the OTS Type 2 also provides easy access on the process side. High turbulence ensures a low risk of fouling on the cooling side. If cleaning is needed, chemical cleaning on the cooling side is very efficient because of the single-channel construction.



OTS Type 2

Mechanical design pressure for all models

Maximum design pressure (barg) as per AD-2000 & ASME*

100°C	150°C	200°C	250°C	300°C	350°C	400°C
8	7.5	7	6.5	6	5.5	5.5

With full vacuum -1 barg

Minimum design temperature -100°C

* Design and manufacturing codes: PED (AD-2000) and ASME VIII Div. 1

Flange specification

Flange	EN 1092-1 02 A	ANSI B16.5 SO 150 LBS
Material	1.4306	316L

Dimensions

OTS	Area m ²	Ø body Dy	Body width	Spacing		Nozzles			B	H	F	G	P
				S _A	S _B	A1/A2	A3	B1/B2					
222	2.9	460	200	5	5	200	50	50	460	1260	680	580	200
244	4.2	460	400	8	8	200	50	80	660	1460	780	680	300
284	8.4	520	400	5	5	250	50	50	660	1460	780	680	300
286	9.4	520	625	8	8	250	50	80	885	1685	890	795	410
2156	15	700	625	8	12	250	80	100	935	1835	990	845	450

OTS	Q	R	Z	W	N	E	D	I	Weight empty kg	Volume	
										VA	VB
222	80	330	200	275	330	50	720	630	200	105	30
244	165	430	185	290	345	50	720	630	220	130	35
284	180	430	230	305	360	50	785	695	300	165	38
286	275	540	215	320	375	50	785	695	330	175	65
2156	265	565	295	420	475	75	975	885	580	325	120

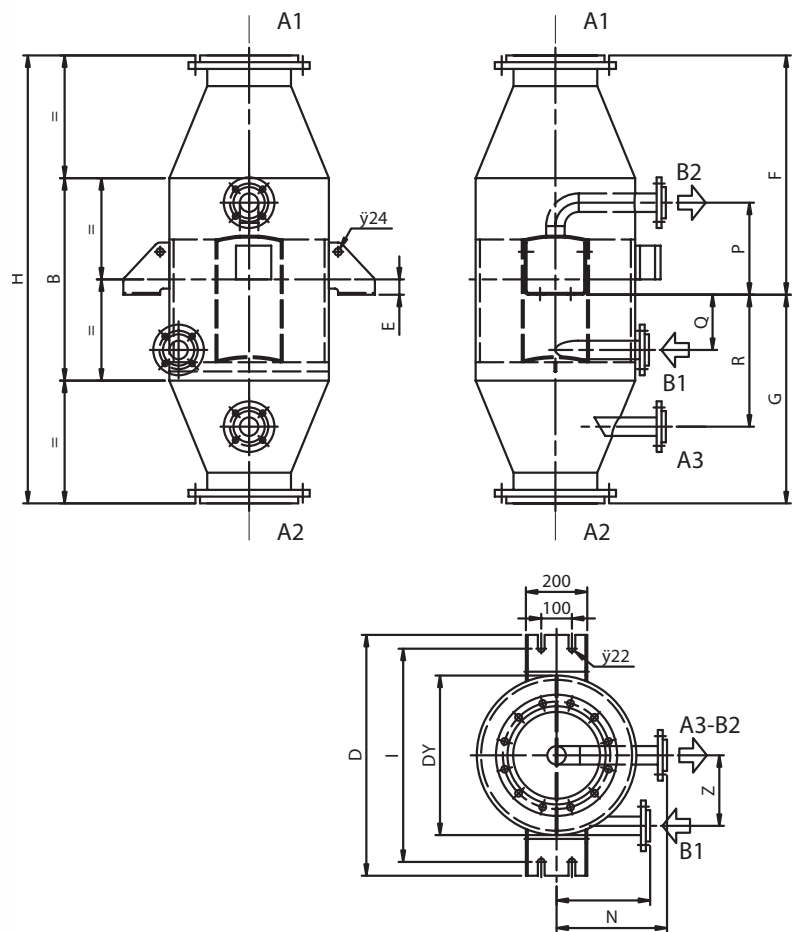
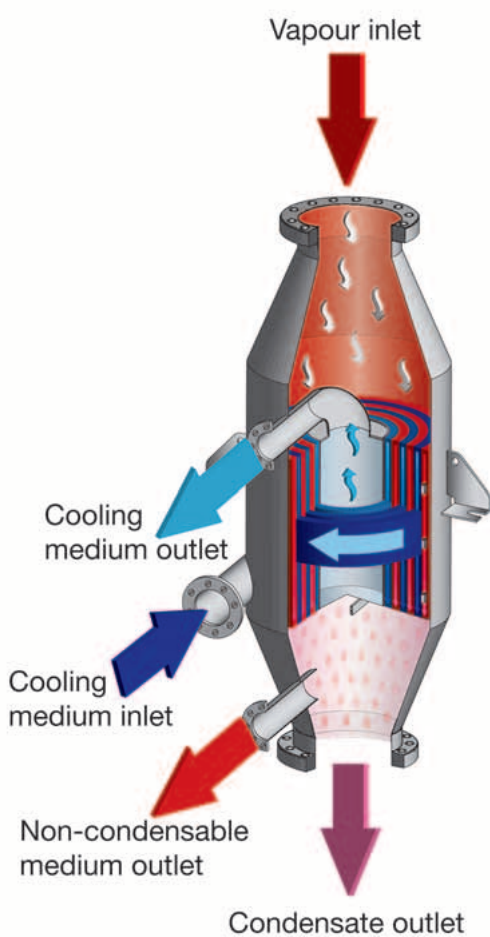

PPM00096EN 0408

Alfa Laval reserves the right to change specifications without prior notification.

How to contact Alfa Laval

Up-to-date Alfa Laval contact details for all countries are always available on our website at www.alfalaval.com